

REP039: The MAX2510 IF Transceiver with the MAX5183 DAC

RF systems, which require direct coupling between the baseband output digital-to-analog converter (DAC) and the input to the I/Q modulator, present a design challenge. This unique requirement of direct coupling does not exist in many RF systems because the modulation and encoding are contrived to avoid the need for DC response at this point in the system. When the need for very low frequency response exists, a way must be found to route the DAC output signal into the I/Q modulator while providing acceptable RF performance. This application note describes tests carried out on the MAX2510 IF transceiver to measure the impact of DC coupling into the modulator, presents the test results, and proposes a simple circuit to provide the DC interface to the MAX5183 DAC.

Rapid engineering prototypes are real circuits that Maxim application engineers have built and measured in our labs. They can provide a starting point for new RF designs. They are not available as evaluation kits.

Additional Information: [Wireless Product Line Page](#)
[Quick View Data Sheet for the MAX2510](#)
[Quick View Data Sheet for the MAX5180/MAX5183](#)
[Applications Technical Support](#)

The MAX2510 is a highly integrated IF transceiver featuring four operating modes for advanced system power management. Typically, the receiver downconverts a high IF/RF (up to 600MHz) to a low IF (up to 30MHz) using a double-balance mixer. Also included in the receiver function are an IF buffer that can drive an off-chip filter, an on-chip limiting amplifier offering 90dB of receive-signal-strength indication (RSSI), and a robust differential limiter output driver designed to directly drive a CMOS input. The transmitter section upconverts I and Q baseband signals to an IF in the 100MHz to 600MHz range using a quadrature modulator.

The MAX5183 is a dual, 10-bit, 40MHz current/voltage output DAC with simultaneous update. It is designed to provide a high level of signal integrity for the least amount of power dissipation. The device has three modes of operation: normal, low-power standby, and complete shutdown.

Often, customer systems require DC response between the MAX5183 DAC, and the I/Q modulator in the MAX2510. When space is limited, a simple interface between the DAC and the modulator is possible, if the impact of DC offset voltages on the I/Q inputs is managed.

This application note presents data showing the impact of modulator I/Q offset voltages on the modulator's RF performance and proposes an interface solution.

Conclusion

The offset voltage at the input of the I/Q modulator impacts the LO suppression. Other modulator performance is only weakly impacted. ~10mV of offset on one modulator input will degrade the LO suppression from -43dBc to -20dBc. Offset voltages of $\pm 20\text{mV}$ on both I and Q inputs degrades the LO suppression to -15dBc.

Bench Test Equipment List

Description	Maker	Model	Serial
Spectrum Analyzer/Mainframe	HP	HP141T	1615A12622
Spectrum Analyzer/RF	HP	HP8555A	1416A03976
Spectrum Analyzer/IF	HP	HP8552B	1437A07067
Signal Generator	HP	HP8640B/01/02/03	1851A09868
Signal Generator	HP	E4432B	US38441362
Oscilloscope	HP	1740A	2026A13971
Power Supply	PowerOne	C5-6 (modified)	N/A
DVM	Fluke	12	51620479

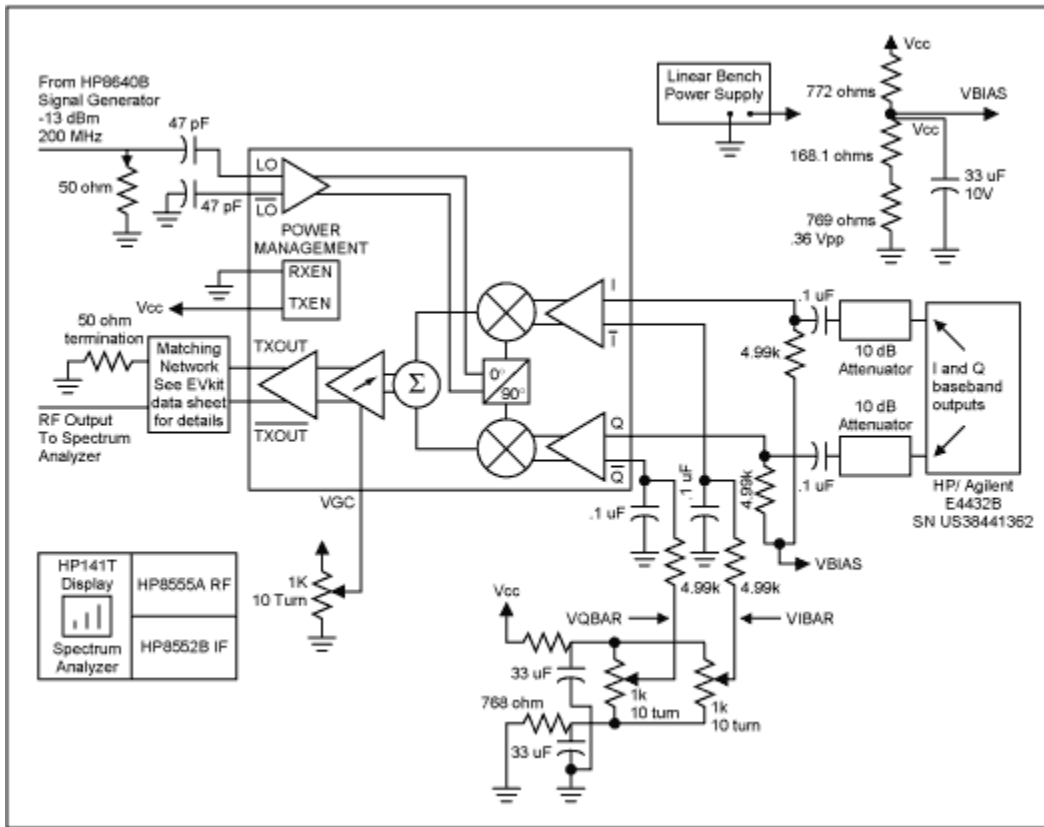

Figure 1. Circuit Modification and Test Set Up.

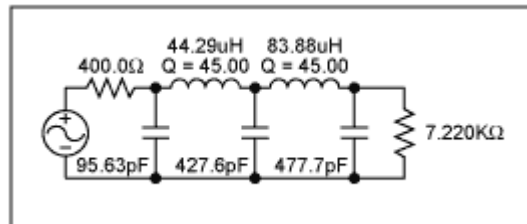

Figure 2. 5th-order low pass Butterworth filter

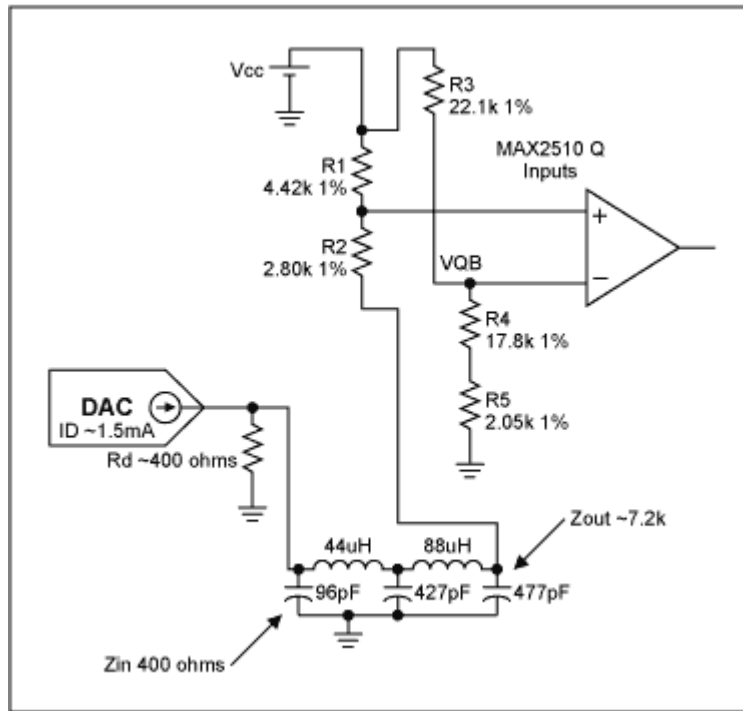

Figure 3. Proposed interface solution

Measured Modulator Performance: Vary Just the Q Offset

Q Offset Voltage (mV)	LO Level (dBc)	I Offset Set for Minimum (mv)	SA Ref. Level	LO	VQ _{pp}	V _{bias}	V _{GC}
0	-43	2	-13dBm	200MHz, -13dBm	.4V	1.890V	2.003V
-4	-28	2	-	-	-	-	-
-9	-22	2	-	-	-	-	-
-19	-15	2	-	-	-	-	-
6	-22	2	-	-	-	-	-
11	-18	2	-	-	-	-	-
21	-13	2	-	-	-	-	-

Measured Modulator Performance: Vary the I Offset

I Offset Voltage (mV)	LO Level (dBc)	Q Offset Set for Minimum (mv)
0	-44	-1
3	-33	-1
8	-23	-1
13	-18	-1
18	-15	-1
-7	-21	-1
-12	-18	-1
-22	-13	-1

Measured Modulator Performance: Vary Both the I and Q Offset

Q Offset Voltage (mV)	I Offset Voltage (mV)	LO Level (dBc)	Lower Sideband (dBc)	2nd Harmonic
-3	2	-44	-40	-34dBc
-20	2	-20	-40	-
-20	20	-17	-40	-
20	20	-16	-40	-
20	-20	-15	-40	-32dBc

Test Condition:

- All tests at room temperature
- Type of modulation: none, CW used.
- Vcc: 3.3V
- VBIAS = 1.809V
- VGC = 2.003V
- LO = 200MHz, -13dBm

MORE INFORMATION

MAX2510: [QuickView](#) -- [Full \(PDF\) Data Sheet \(176k\)](#) -- [Free Sample](#)

MAX5183: [QuickView](#) -- [Full \(PDF\) Data Sheet \(320k\)](#) -- [Free Sample](#)